

Countermeasures Optimization in Multiple Fault-Injection Context

Journée thématique sur les attaques par injection de fautes 2020

Etienne Boespflug, Cristian Ene
Laurent Mounier, Marie-Laure Potet

September 24, 2020

VERIMAG

`name.lastname@univ-grenoble-alpes.fr`

Supported by SECURIOT-2-AAP FUI 23 and by ANR-15-IDEX-02



- 1 Context
- 2 Countermeasure Optimization
- 3 Experimentation
- 4 Conclusion

An example: verifyPIN

```

1  BOOL byteArrayCompare(UBYTE* a1, UBYTE* a2,
   UBYTE size) {
2  BOOL result = BOOL_TRUE;
3  UBYTE i;
4  for(i = 0; i < size; i++) {
5      if(a1[i] != a2[i]) {
6          result = BOOL_FALSE;
7      }
8  }
9
10 if(i != size)
11     killcard();
12
13 return result;
14 }
15
16 BOOL verifyPIN() {
17     if(g_ptc > 0)
18         if(byteArrayCompare(g_userPin,
19                             g_cardPin, PIN_SIZE) == BOOL_TRUE) {
20             // Authentication();
21             g_authenticated = 1;
22             g_ptc = 3;
23             return BOOL_TRUE;
24         } else {
25             g_ptc--;
26             return BOOL_FALSE;
27         }
28     return BOOL_FALSE;
29 }

```

```

1  /** Lazart analysis instrumentation main
   function. */
2
3  int main()
4  {
5      verifyPIN();
6
7      LAZART_ORACLE(g_killcard == 0 && g_authenticated ==
8                    1);
9      return 0;
10 }

```

- **Functionality:** user authentication with secret PIN code
- **Attack objective:** authenticate with an incorrect user PIN



Lazart: source level analysis for multiple faults injection

⇒ **Lazart**¹ is a LLVM-level code robustness evaluation tool against multi-faults injection based on concolic execution (Klee)

- **Objectives:** Help developer/auditor to find attack paths and evaluate counter-measures.

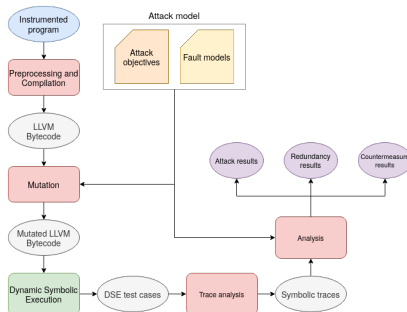

¹M.-L. Potet, L. Mounier, M. Puys, and L. Dureuil, "Lazart: Asymbolic approach for evaluation the robustness of secured codes against control flow injections,"



verifyPIN - Attack results

■ Analysis parameters:

- **Inputs:** Incorrect PIN
- **Attack objective:** being authenticated with a false PIN
- **Fault model:** up to N **test inversions**

| Fault limit (N) | 0 | 1 | 2 | 3 | 4 |
|-----------------|---|---|---|---|---|
| Attacks | 0 | 1 | 1 | 0 | 1 |

- A successful 2-order attack (right) inverts the loop's condition $i < \text{size}$ and the later check $\text{if}(i \neq \text{size}) \text{killcard}()$;

Figure: The 2-faults attack (Test Inversion)

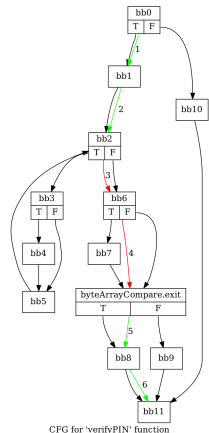

Definitions - Countermeasure

A **countermeasure** (in red) is a program transformation which:

- preserves its observable behavior without faults
- increases security in presence of faults
- Trade off between security and performance (speed, memory, size...)

```

1  BOOL byteArrayCompare(UBYTE* a1, UBYTE* a2,
2  UBYTE size, UBYTE size_dup) {
3  int i;
4  BOOL result = BOOL_TRUE;
5  BOOL result_dup = BOOL_TRUE;
6
7  for(i = 0; i < size; i++) {
8      if(a1[i] != a2[i])
9          result = BOOL_FALSE;
10     if(a1[i] != a2[i])
11         result_dup = BOOL_FALSE;
12
13     if(result != result_dup)
14         killcard();
15 }
16
17 if(i != size)
18     killcard();
19 if(i != size_dup)
20     killcard();
21
22 return result;
23 }
```



Countermeasures

We consider **Detective** countermeasures, with side-effect free tests.

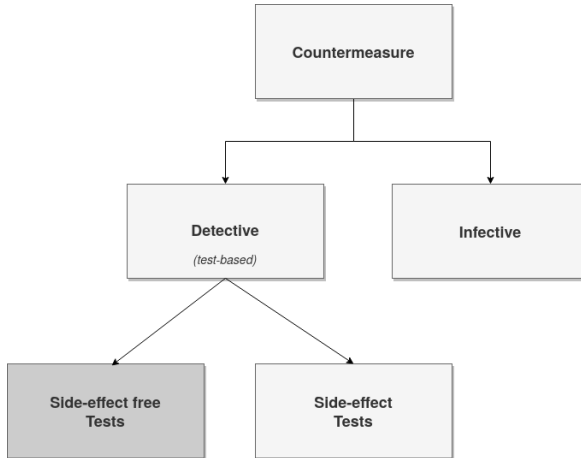

Definitions - CCPs and structures

We divide a **detective countermeasure** in two parts:

- **Countermeasure Check Points (CCPs)** are control point in the program corresponding to sanity checks about the current state
- The **countermeasure's structures**: shadow variables, parameters, additional computation etc.

```

1  BOOL byteArrayCompare(UBYTE* a1, UBYTE* a2,
2  UBYTE size, UBYTE size_dup) {
3  int i;
4  BOOL result = BOOL_TRUE;
5  BOOL result_dup = BOOL_TRUE;
6
7  for(i = 0; i < size; i++) {
8  if(a1[i] != a2[i])
9  result = BOOL_FALSE;
10 if(a1[i] != a2[i])
11 result_dup = BOOL_FALSE;
12
13 if(result != result_dup)
14 killcard();
15 }
16
17 if(i != size)
18 killcard();
19 if(i != size_dup)
20 killcard();
21
22 return result;
23 }
```

Objectives:

- determine if some **CCPs** could be removed
- remove related **countermeasure's structures**



Test Duplication - An example of Detective Countermeasure

- Designed for *Control Flow Integrity*
- Branching conditions are duplicated

Table: Test duplication vs Non-protected version on verifyPIN

Source CFG

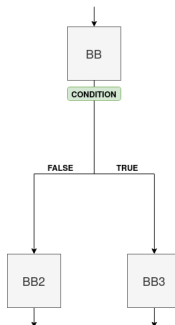

Test Duplication

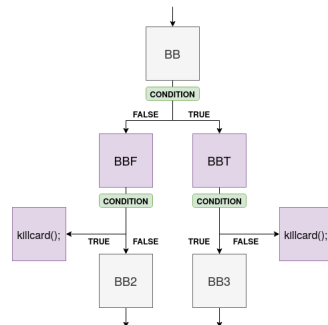

| Program / Fault Count | 0 faults | 1 fault | 2 faults | 3 faults | 4 faults |
|-----------------------|----------|---------|----------|----------|----------|
| Non-protected | 0 | 1 | 1 | 0 | 1 |
| Test Duplication | 0 | 0 | 1 | 0 | 1 |



- 1 Context
- 2 Countermeasure Optimization**
- 3 Experimentation
- 4 Conclusion

Countermeasure Optimization Methodology

Goal: reduces the number of **CCPs** in a protected program without introducing new attacks

Methodology:

Input: a program P and attack model (fault model + attack objectives)

Output: a program P'

- 1 Generate the set of detected successful attack traces for P (successful regarding to attack objectives and blocked by at least a CCP)
- 2 Compute the **CCP Classification**
- 3 Choose a *removal strategy* and use **CCP selection algorithm** to find the optimal sets of CCP to be removed
- 4 Remove countermeasure's structures (variables, parameters...) related to the selected CCPs and generate the program P'

P' is the optimized protected version of P



Input Program - Test duplication on verifyPIN

Two **CCP** are generated for each conditional branching

```

1  BOOL byteArrayCompare(UBYTE* a1, UBYTE* a2,
   UBYTE size) {
2  BOOL result = BOOL_TRUE;
3  int i;
4  for(i = 0; i < size; i++) { // CCP 2 & CCP
   3
5      if(a1[i] != a2[i]) { // CCP 4 & CCP 5
6          result = BOOL_FALSE;
7      }
8  }
9
10 if(i != size) // CCP 6 & CCP 7
11     killcard(100); // CCP 100
12
13 return result;
14 }
```

```

1  BOOL byteArrayCompare(UBYTE* a1, UBYTE* a2,
   UBYTE size) {
2  BOOL result = BOOL_TRUE;
3  int i;
4  BOOL c_1 = false;
5
6  for(i = 0; BOOL c_1 = i < size; i++) {
7      if(!c_1)
8          killcard(); // CCP 2
9      if(BOOL c_2 = a1[i] != a2[i]) {
10         if(!c_2)
11             killcard(); // CCP 4
12         result = BOOL_FALSE;
13     } else
14         if(c_2)
15             killcard(); // CCP 5
16     }
17     if(c_1)
18         killcard(); // CCP 3
19
20     if(BOOL c_3 = i != size) {
21         if(!c_3)
22             killcard(); // CCP 6
23         killcard(); // CCP 100
24     }
25     } else
26         if(c_3)
27             killcard(); // CCP 7
28
29     return result;
30 }
```



Methodology - Step 1 & 2 - CCP classification on traces

The classification step considers the set A of attack traces (**step 1**) that are both:

- *successful*: satisfies the attack objectives
- *blocked*: at least one **CCP** is triggered

- We associate with each symbolic trace t a **repetition level** $L(t)$ as the number of **different** CCPs triggered

- Classify each **CCP** C_i according to its *Minimal Repetition Level*:

$$L_m(C_i) = \min\{L(t) \mid t \in A \text{ and } C_i \text{ is triggered in } t\}$$

- **Inactive**: if $L_m(C_i) = \infty$ (never triggered)
- **Necessary**: if $L_m(C_i) = 1$
- **Repetitive**: otherwise, if $1 < L_m(C_i) < \infty$

- **Inactive** CCPs are removed

- If **Repetitive** CCPs are found, need to determine which of them should be removed



Methodology - Step 1 & 2 - Test Duplication results in 2 faults

VerifyPIN + Test Duplication:

- 86 traces in 2 faults with **Lazart**

Table: Test duplication CCP classification in 2 faults

| CCP | 0 | 1 | 2 | 3 | 4 | 5 | 6 | 7 | 8 | 9 | 100 |
|-------|---|---|---|---|---|---|---|---|---|---|-----|
| Class | R | I | R | R | R | R | R | R | N | I | N |

```

1  BOOL verifyPIN() {
2      if(g_ptc > 0)          CCP 0 & CCP 1
3          if(byteArrayCompare(g_userPin, g_cardPin
4              , PIN_SIZE) == BOOL_TRUE) { CCP
5              8
6                  g_authenticated = 1;
7                  g_ptc = 3;
8                  return BOOL_TRUE;
9          } else { CCP 9
10             g_ptc--;
11             return BOOL_FALSE;
12         }
13     return BOOL_FALSE;
14 }

```

```

1  BOOL byteArrayCompare(UBYTE* a1, UBYTE* a2,
2      UBYTE size) {
3      BOOL result = BOOL_TRUE;
4      int i;
5      for(i = 0; i < size; i++) { CCP 2 & CCP 3
6          if(a1[i] != a2[i]) { CCP 4 & CCP 5
7              result = BOOL_FALSE;
8          }
9      }
10     if(i != size) CCP 6 & CCP 7
11         killcard(100); CCP 100
12
13     return result;
14 }

```



Methodology - Step 3 - CCP Selection algorithm

- **Objective:** compute the optimal sets of CCP to keep
- **Input:** The CCP classification, the attack traces and a weight function

Selection algorithm:

- 1 Let S a function associating a **weight** to a CCP (user-provided)
- 2 A set of CCP R_i is **valid** if for each trace t , at least one CCP in R_i is triggered
- 3 Lift the weight function S to sets of CCP R_i as $W_{R_i} = \sum_{CCP_i \in R_i} S(CCP_i)$
- 4 Find the sets with the **minimal weight**



Methodology - Step 4 - Structures Removal

- When the set of removed **CCPs** has been computed, unused *countermeasure's* structures can be removed
- Correspond to useless code elimination, can be done with a compiler or static analysis tools (Clang, GCC, Frama-C...)
- The program P' generated is equivalent to P if the initial set of traces is representative



Step 4 - Removed CCPs for verifyPIN (2 faults)

The **removed** and **kept** structures of *Test* duplication on verifyPIN for 2 faults

```

1  BOOL verifyPIN() {
2      if(BOOL c_1 = g_ptc > 0) {
3          if(!c_1)
4              killcard();
5
6          if(BOOL c_2 = byteArrayCompare(g_userPin,
7              g_cardPin, PIN_SIZE) == BOOL_TRUE
8              ) {
9              if(!c_2)
10                 killcard();
11                 g_authenticated = 1;
12                 g_ptc = 3;
13                 return BOOL_TRUE;
14             } else {
15                 if(c_2)
16                     killcard();
17                 g_ptc--;
18                 return BOOL_FALSE;
19             }
20         } else
21             if(c_1)
22                 killcard();
23     }
24     return BOOL_FALSE;
25 }

```

```

1  BOOL byteArrayCompare(UBYTE* a1, UBYTE* a2,
2      UBYTE size) {
3      BOOL result = BOOL_TRUE;
4      if i;
5      BOOL c_1 = BOOL_FALSE;
6
7      for(i = 0; BOOL c_1 = i < size; i++) {
8          if(!c_1)
9              killcard();
10         if(BOOL c_2 = a1[i] != a2[i]) {
11             if(!c_2)
12                 killcard();
13             result = BOOL_FALSE;
14         } else
15             if(c_2)
16                 killcard();
17     }
18     if(c_1)
19         killcard();
20
21     if(BOOL c_3 = i != size) {
22         if(!c_3)
23             killcard();
24         killcard();
25     } else
26         if(c_3)
27             killcard();
28
29     return result;
30 }

```



CCP's Properties

CCP's properties:

- The control flow must continue as if the CCP was not present
→ allows to don't stop path exploration when a CCP is triggered.
- Side-effect free (condition evaluation and killcard-like command)

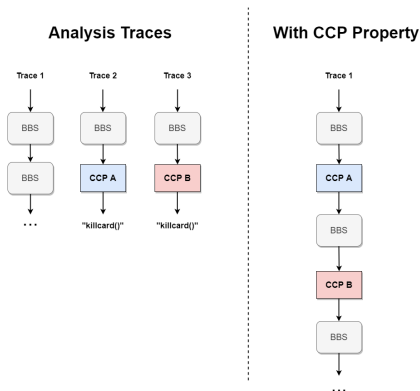

1 Context

2 Countermeasure Optimization

3 Experimentation

4 Conclusion

Experimentations - Traces generation

Traces generation with **Lazart**:

- LLVM level
- Traces generated with *Dynamic Symbolic Execution*

Using *Test inversion* model



Experimentations - Test programs

Tested programs:

- *verifyPIN* (**VP**): smart-card PIN verification process
- *Firmware Updater* (**FU**): updates a firmware from remote source
- *Get Challenge* (**GC**): this program is an example of a nonce generation. The security property asserts that the nonce is updated with a randomly generated value
- *AES Cipher* (**AES**): implementation of AES encryption scheme. The isolated *AddRoundKey* (**AK**) step is also considered



Experimentations - Countermeasures

Three countermeasures experimented:

- *Test duplication (TD)*: presented previously
- *SecSwift Control Flow (SSCF)*²: associates an unique identifier to each basic block and uses a xor-based mechanism to ensure that the correct branch has been taken
- **LBH**³: introduce step counters to protect against C-level instruction skips. Each counter verification is a CCP

²François de Ferrière. «A compiler approach to Cyber-Security». 2019.

³Lalande, J.F., Heydemann & al. 2014 «Software countermeasures for control flow integrity of smart card C codes». In European Symposium on Research in Computer Security



Experimentation results

Table: Percentage of removed CCP for each experimentation

| Program | CCP | 1 fault | 2 faults | 3 faults |
|---------------|-----|---------|----------|----------|
| VP + TD | 11 | 72% | 63% | 18% |
| VP + SSCF | 13 | 92% | 76% | 23% |
| VP + LBH | 31 | 93% | 93% | 32% |
| FU + TD | 14 | 0% | 0% | 0% |
| FU + SSCF | 24 | 12% | 12% | 8% |
| GC1 + TD | 39 | 37% | 34% | 34% |
| GC1 + SSCF | 38 | 57% | 28% | 28% |
| AES RK + TD | 2 | 50% | 50% | 0% |
| AES RK + SSCF | 3 | 66% | 33% | 0% |
| AES C + TD | 8 | 50% | 50% | 0% |
| AES C + SSCF | 13 | 76% | 61% | 38% |



Experimentation results - Playing with the Attack objectives

The **attack objective** strongly impacts the removed **CCPs**.

- ϕ_{auth} : being authenticated with a false PIN.
- ϕ_{ptc} : do not decrement the try counter with a false PIN.

Table: Removed CCP depending on attack objective (VP + TD)

| Property | 1 fault | 2 faults | 3 faults |
|--------------------------|---------|----------|----------|
| ϕ_{auth} | 83% | 72% | 18% |
| ϕ_{ptc} | 72% | 63% | 9% |
| $\phi_{auth} \wedge ptc$ | 83% | 72% | 18% |
| $\phi_{auth} \vee ptc$ | 72% | 63% | 9% |
| ϕ_{true} | 18% | 9% | 9% |



Experimentation results - Time metrics

Table: Time metrics in 3-faults

| Program | DSE (h) | Completed Paths | Traces | CCPO |
|---------------|---------|-----------------|--------|-------|
| VP + TD | 0:00:03 | 7118 | 296 | 26ms |
| VP + SSCF | 0:01:54 | 130 576 | 1005 | 89ms |
| VP + LL | 0:38:24 | 1 173 312 | 37 347 | 371ms |
| FU + TD | 0:39:16 | 935 409 | 43 328 | 736ms |
| FU + SSCF | 1:04:39 | 1 490 767 | 91 713 | 4s |
| GC1 + TD | 0:01:35 | 102 169 | 10 281 | 1s |
| GC1 + SSCF | 0:31:45 | 1 048 354 | 58 367 | 2s |
| AES RK + TD | 0:00:07 | 9 439 | 847 | 61ms |
| AES RK + SSCF | 0:09:19 | 410 095 | 6 952 | 195ms |
| AES C + TD | 1:17:25 | 1 064 007 | 38 810 | 575ms |
| AES C + SSCF | 1:45:00 | 842 583 | 29 770 | 2s |



1 Context

2 Countermeasure Optimization

3 Experimentation

4 Conclusion

Conclusion

- A methodology to *optimize* program protected by CCP-based countermeasures
- Experimental results are very promising (up to 80% of CCPs removed)
- Only one DSE exploration → realistic analysis time for real world programs
- The methodology is generic regarding to the analysis level and trace generation method



Future work

- Assisted countermeasure placement
- Analysis of countermeasure outside of context
- Validate on further code examples (programs, libraries, fault models)



Test Inversion model

- Each conditional branching can be inverted (forcing the control flow to the wrong branch)
- Parameterized by a faults bound (here 3)
- Close to developer logic
- Maps to several low-level attacks:
 - NOP branching instruction
 - Faulting condition register
 - Jump to desired BB
 - ...

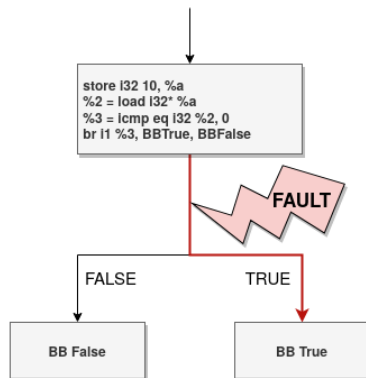

Test Duplication - CCP Instrumentation

The *Test Duplication* scheme is slightly instrumented to respect CCP properties.

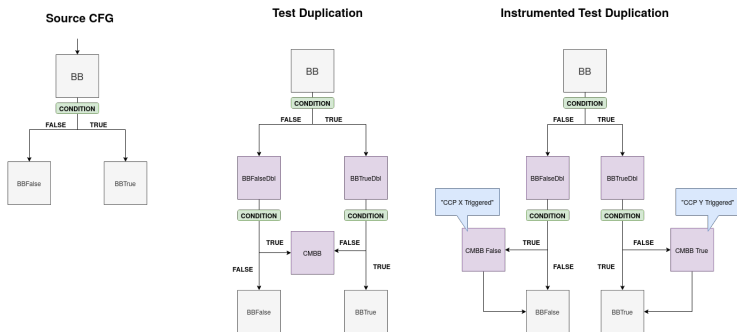

SecSwift Control-Flow

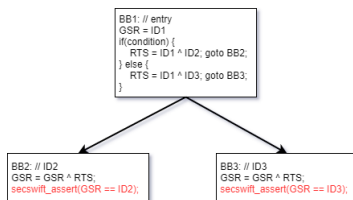

SecSwift ControlFlow⁴ is one of the 3 parts of SecSwift

- Designed for Control-Flow Integrity (CFI)
- Uses static signature for each basic block and propagate errors
- Each secswift_assert is a **CCP**



⁴François de Ferrière. «A compiler approach to Cyber-Security». 2019.

LBH's countermeasure⁵

```

1  #define INCR(cnt, val) cnt = cnt + 1;
2  #define CHECK_INCR(cnt, val, cm_id) if (cnt != val) countermeasure(cm_id); \
3      cnt = cnt + 1;
4  [...]
5
6
7  BOOL verifyPIN(unsigned short* CNT_0_VP_1)
8  {
9      CHECK_INCR(*CNT_0_VP_1, CNT_INIT_VP + 0, OLL)
10     g_authenticated = 0;
11     CHECK_INCR(*CNT_0_VP_1, CNT_INIT_VP + 1, 1LL)
12     DECL_INIT(CNT_0_byteArrayCompare_CALLNB_1, CNT_INIT_BAC)
13     CHECK_INCR(*CNT_0_VP_1, CNT_INIT_VP + 2, 2LL)
14     BOOL res = byteArrayCompare(g_userPin, g_cardPin, PIN_SIZE, &CNT_0_byteArrayCompare_CALLNB_1);
15     [...]

```

- Insert *step-counters* for each C construct
- *Checking macros* (such as `CHECK_INCR`) are **CCPs**
- Analysis allows to know where the counter verification can be removed

⁵Lalande J.F. & al. 2014 «Software countermeasures for control flow integrity of smart card C codes». In European Symposium on Research in Computer Security

